



IQ DOUBLE QALIZER

USER'S MANUAL

IGS Audio Igor Sobczyk
3 Maja 76d, 41-400 Mysłowice, Poland
e-mail: igs@o2.pl ph: +48 601 597 592

www.igsaudio.com

Please read all of the following instructions and save them for later reference before attempting to connect the unit to the mains.

EARTH

This unit is connected via its power cord to the mains safety earth.
NEVER OPERATE THE UNIT WITH THIS EARTH CONNECTION REMOVED.

COVERS

DO NOT remove the covers. Refer servicing to qualified personnel only.

VOLTAGE

Unit is set to operate only at the voltage indicated on the PSU unit
CHECK that the correct voltage is selected before connecting the AC mains supply.

FUSES

CHECK that the fuse fitted is the correct type for the local mains voltage.
ALWAYS replace fuse with the correct type.

MOISTURE

DO NOT expose the unit to rain or moisture. If the unit should become so exposed **REMOVE** the mains power immediately.

CABLES

PROTECT the mains power cord from damage through impact or abrasion.

HEAT

ALWAYS site the unit away from sources of heat including direct sunlight and ensure adequate ventilation around the unit.

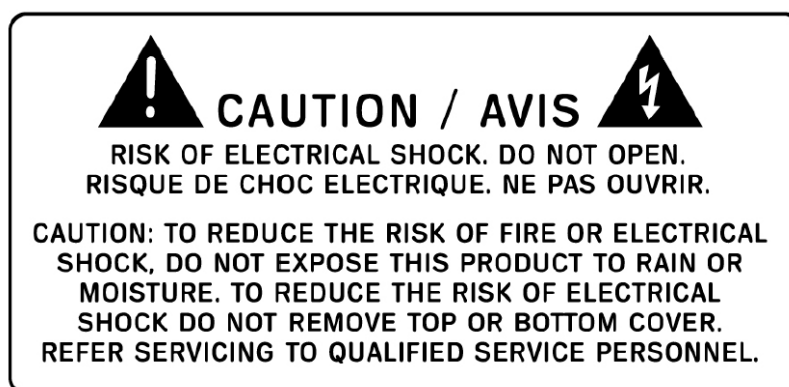

Copyright 2014. All rights reserved.

The information in this document is subject to change without notice.

IGS Audio makes no warranty of any kind with respect to the material in this document and shall not be liable for errors contained herein or for incidental or consequential damages related to the use of the material.

Manual revision: 1.0 (December 2014)



Thank you for buying this IGS Audio product.

Please read the information provided below very carefully before using your IGS unit.

Unpacking

Your IQ has been carefully and meticulously tested and inspected before dispatch. Please check for any signs of transit damage. If any signs of mishandling are found please notify the carrier and your dealer immediately.

Your IQ packing should contain an IQ with IGS Audio tag and this manual with the Warranty and RoHS/CE/WEEE Declaration attached.

Compatibility and Power

There is a fuse socket near the power cable connector on the unit. Ensure that the correct fuse is being used before plugging the IQ to the power outlet.

- ➔ For US area (115V) use 630mA Slow Blow (Type T).
- ➔ For Europe and rest of the world area (230V) use 315mA Slow Blow (Type T).

Always check the voltage selector on the unit to ensure that it is set to the proper voltage available in your country.

IGS AUDIO IQ – stereo active equalizer

IGS IQ Double Qualizer is a modern application of the noble sound of analog correctors. This very precise, parametric equalizer works great on every stage of production. It can add marvelous color to the signal, while maintaining the whole character of the original sound. This is a unique phenomenon possible only with analog processing. As opposed to digital application correction it maintains neutrality and clarity in every setting. The simultaneous boosting and cutting of similar frequencies are the core secret of this device.

This is the typical effect of analog filters in the audio path. Most of the sound correction is in micro-manipulation. The frequency range is divided into 4 bands: Sub, Bass, Mid, High. In every band the frequency and boost/cut level can be set.

Band 1 (SUB): 50-300 Hz (shelf)

Band 2 (LOW): 60-1k Hz (peak)

Band 3 (MID): 1k-16k Hz (peak)

Band 4 (HIGH): 2k-10k Hz (shelf)

Typical usage:

- Great mastering equalizer, due to its excellent channel convergence.
- Very good on vocals, guitars and strings – adds fat bottom and crispy high frequencies

Block diagram

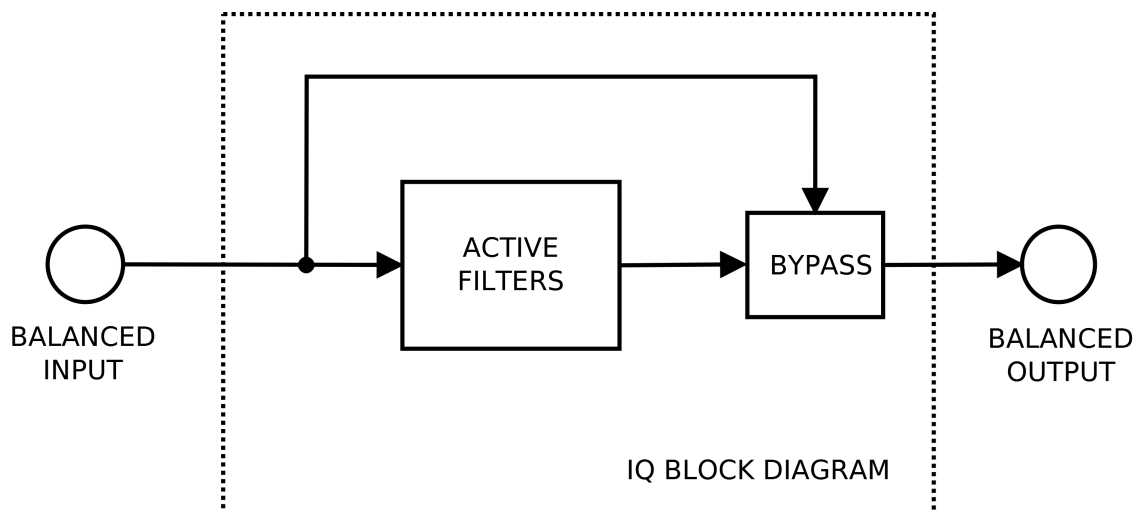

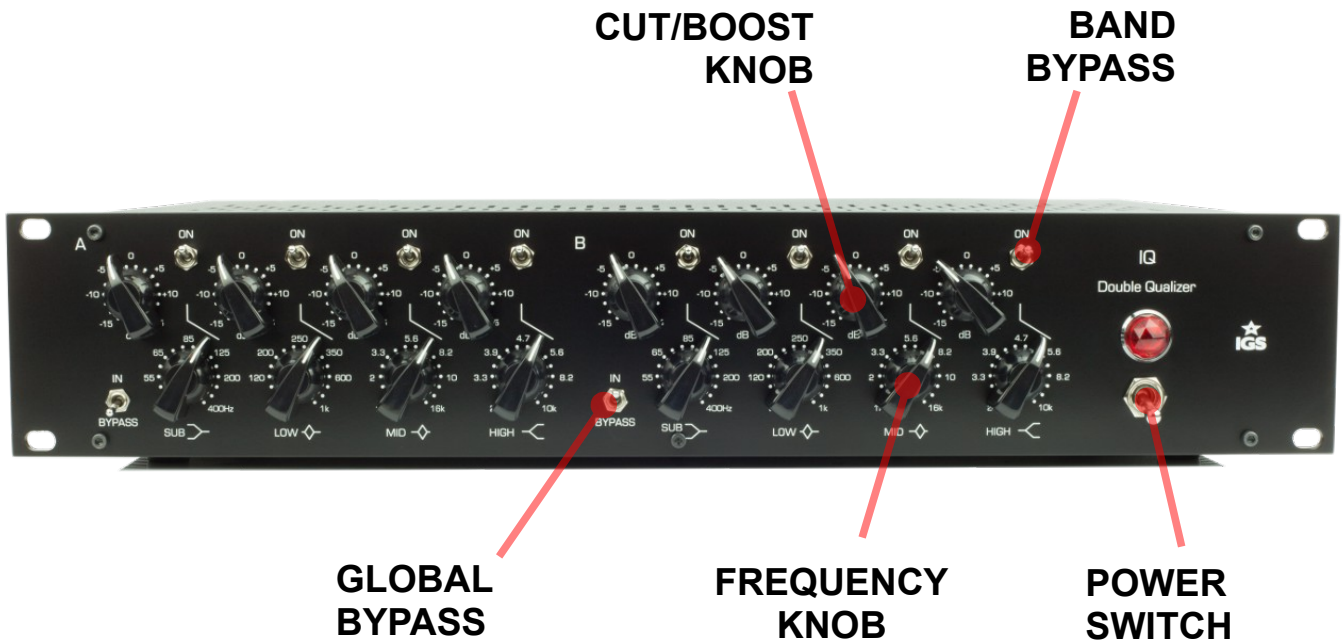

POWER SWITCH AC power switch

FREQUENCY KNOB Frequency of each of the filters

CUT/BOOST KNOB Amount of boost or cut applied to certain frequency

BAND BYPASS Switch of certain bands to A-B the final results

GLOBAL BYPASS Eq IN/BYPASS switch

IQ main functions and technical specification:

- active dual mono equalize
- XLR, balanced inputs/outputs,
- Smooth control for cut/boost knobs
- Stepped frequency control for all bands,
- True Bypass switch

Operating Level	+4 dBu
Maximum Input	+22 dBu
Maximum Output	+22 dBu
EQ boost/cut range	15 dB
Input impedance	10 kOhm
Output Impedance	10 kOhm
Frequency response	20Hz to 20kHz; +/- 0.1dB
Band amplification	+/-15 dB
Bandwidth Range (Q)	0.4 to 5
Power consumption	25 Watts
Shipping weight	4 kg
Dimensions	2U 19 inches, 230mm deep

Troubleshooting

The signal plays thru but there is no change in signal when i turn the knobs:

- Please check the Bypass switch – should be set to IN
- check the individual band bypass switches

No signal plays thru the unit, regardless the settings at the front panel:

- Please check the cables connecting the unit.

The sound coming out of the unit is very distorted:

- Check the input signal level (if too high the unit might saturate the sound, especially when LF boost is high)

Warranty:

This device is declared to be free from defects in material and workmanship for a period of three years. Any device found defective within three years from the delivery date and returned to the factory, will be repaired, adjusted, or replaced and sent to the customer with no charge. The customer always pays the shipping cost to us. This warranty does not cover expendable items such as tubes or fuses. If the defect has been caused by a misuse or abnormal operation conditions, the repair will be billed at a nominal cost. The product should be returned in its original package, if this is possible, or packed in such a way that it is not damaged during the shipment. We are not to be held responsible for any damages during the shipment. All units shall always be packed in a box with support for the rack ears. All 500 series modules need to be secured in ESD bag and protected with foam. We will charge the customer €20 + VAT if the packing material needs to be replaced. If we find that the product works perfectly, the customer will be invoiced €50 + VAT to cover our costs of examination and handling plus the cost for returning the product to the customer.

